

THIS DRAWING CONSTITUTES THE CONFIDENTIAL INFORMATION OF HELIODYNE INC. AND ITS RECEPTOR POSSESSION DOES NOT CONFER ANY RIGHT IN OR LICENSE TO USE IT OR THE INFORMATION DISCLOSED HEREIN NOR ANY RIGHT TO REPRODUCE THIS DRAWING OR ANY PART HEREIN WITHOUT THE WRITTEN CONSENT OF HELIODYNE INC.

ZONE	ECO	REV	DESCRIPTION OF CHANGE	DATE	APPROVED
ALL	N/A	01	PRE-PRODUCTION RELEASE	06/13/08	

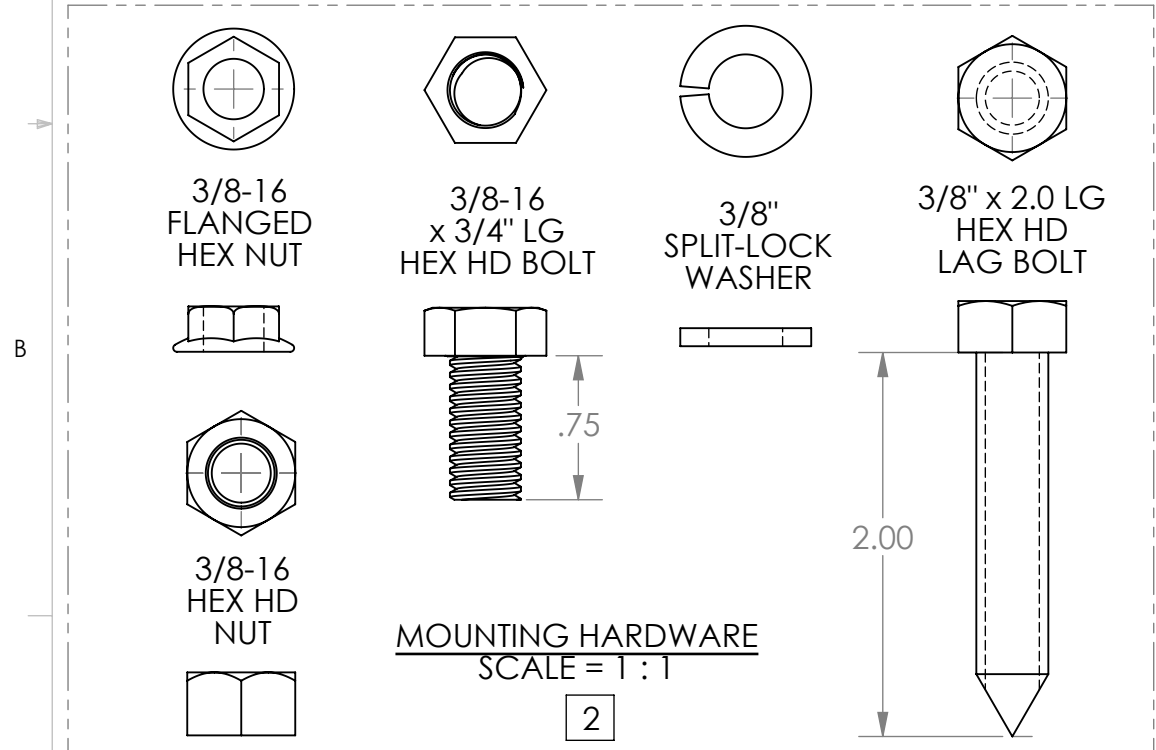
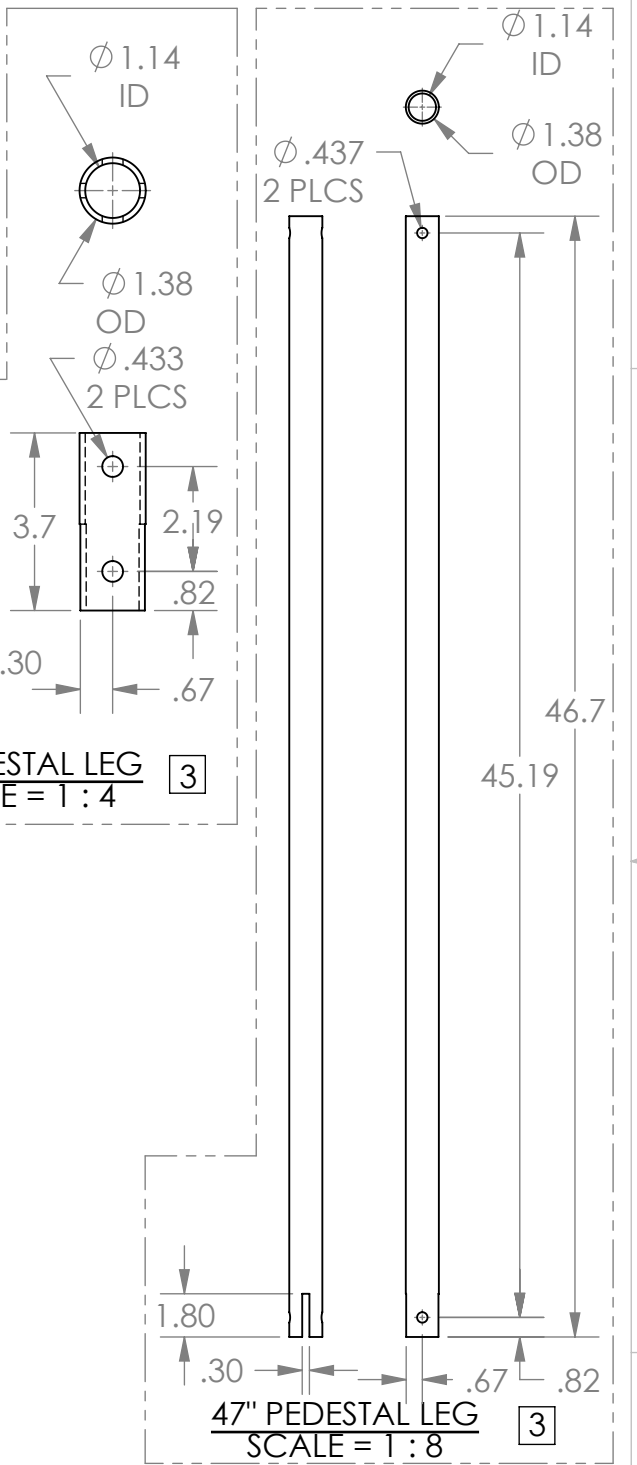
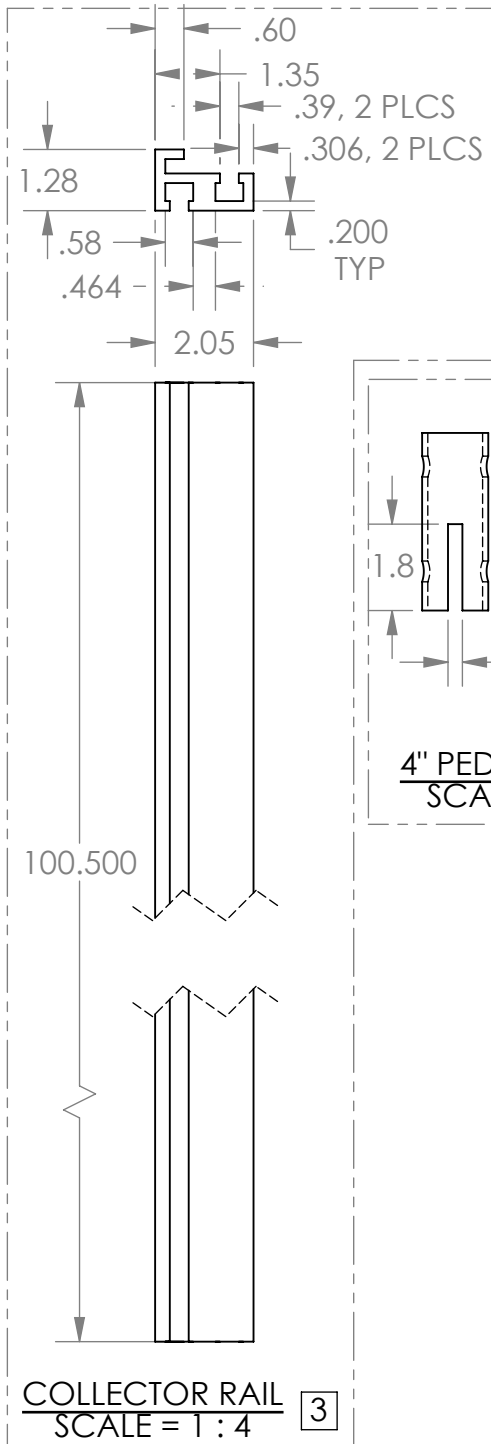
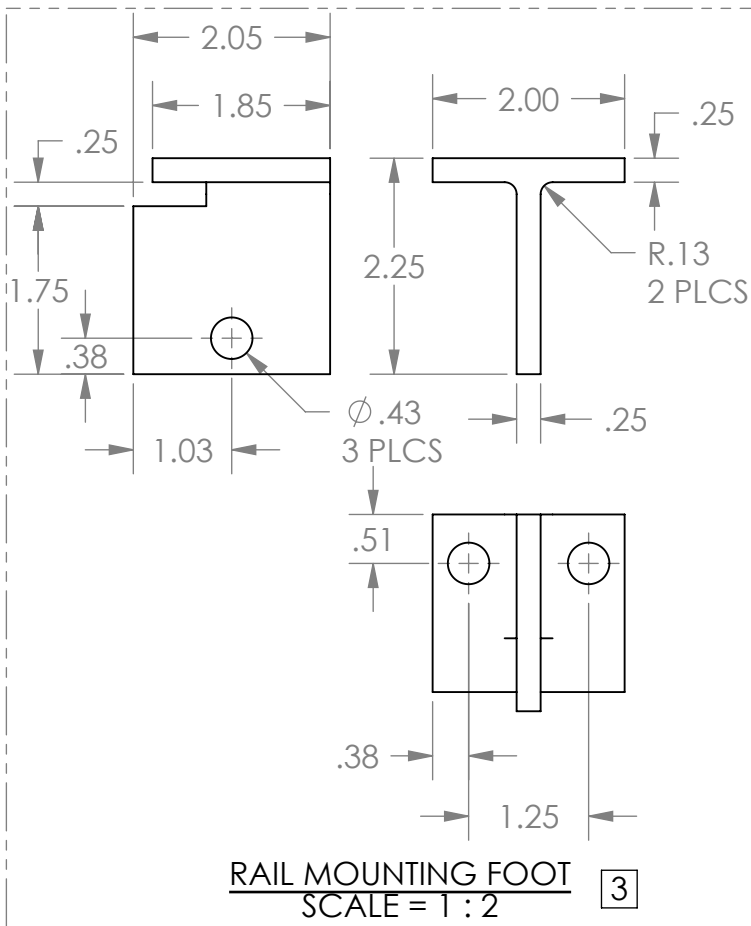
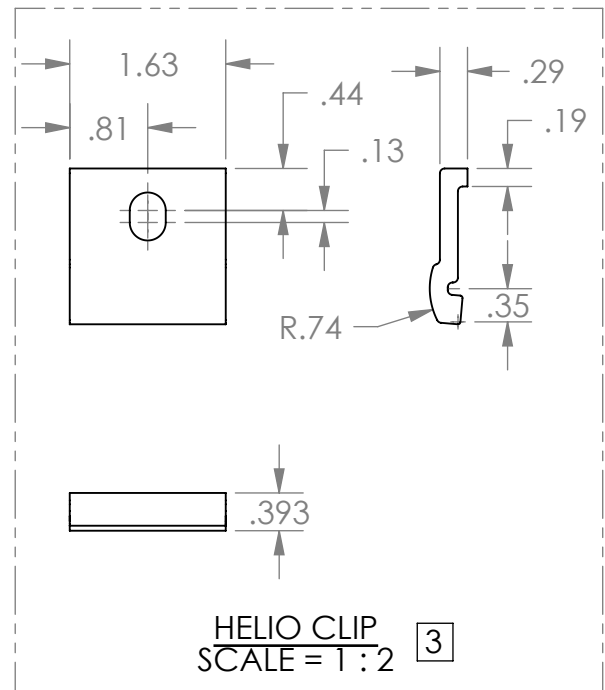
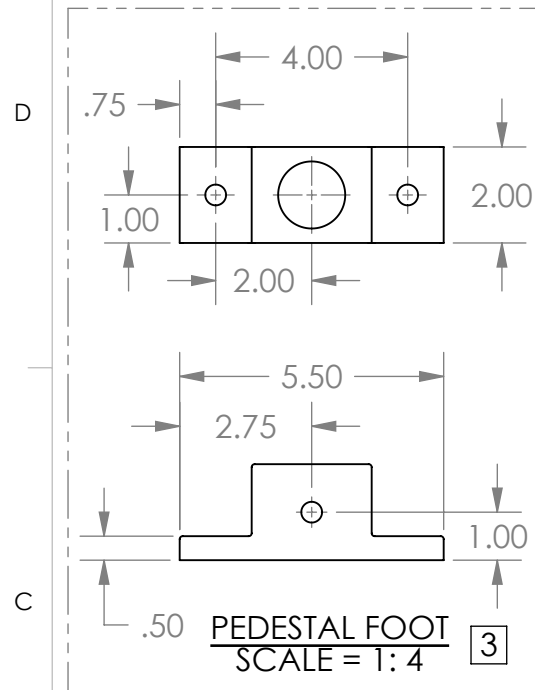

- 3 ALL COMPONENTS OTHER THAN FASTENERS ARE MADE FROM 6063-T6 ALUMINUM ALLOY.
 - 2 ALL FASTENERS ARE MADE FROM 18-8 STAINLESS STEEL w/BLACK OXIDE FINISH.
 - 1. INTERPRET DRAWING PER ANSI/ASME Y14.5 & Y14.35M. DIMENSIONS AND TOLERANCES PER ANSI/ASME Y14.5M-1994.
- NOTES: (unless otherwise specified)

UNLESS OTHERWISE SPECIFIED DIMENSIONS ARE IN INCHES TOLERANCES ARE:		NAMES	DATE	<p>heliodyne SOLAR HOT WATER Heliodyne Inc. 4910 Seaport Ave., Richmond, CA 94804</p>
DIMENSIONS: X = ±.030, XX = ±.010, XXX = ±.005		DRAWN BY:	JD Waters	
ANGLES: X° = 1°, XX° = 1/2°, XXX° = 1/4°		CHECKED BY:		
DO NOT SCALE DRAWING		ENG APP'D:		
MATERIAL:		MFG APP'D:		
FINISH:		Q.A. APP'D:		
NEXT ASSY	USED ON	COMMENTS:		
THIRD ANGLE PROJECTION				
APPLICATION		TITLE		
		TWO COLLECTOR RACK MOUNT LAYOUT		
SIZE	PREFIX	DWG NO	REV	
B	LD	000006	01	
SCALE: SEE DETAILS		WEIGHT:	SHEET: 3 OF 3	