

COMMERCIAL SOLAR STATION

The Heliodyne Commercial Solar Station (HCOM) is a plug & play, closed loop, heat-transfer system. Available in 4 different sizes, each system is designed to handle a specified maximum number of GOBI flat plate collectors. System features include Pressure Stagnation Protection (PSP), a unique Heliodyne feature that helps maintain glycol integrity, variable speed pumps for reduced maintenance and better performance, and internet connectivity for remote system monitoring. For very large installations, HCOM systems can be combined in parallel.

HOW IT WORKS

An HCOM heat-transfer system connects directly to the solar storage tank and GOBI flat plate array, using external isolation valves. An expansion tank, sized to system requirements and not included with the purchase, is also attached in the configuration. As a plug & play unit, each HCOM installation requires less labor while ensuring high quality connections. WiFi / Ethernet connectivity or optional touchscreen control makes it easy to customize settings for optimum performance based on environmental conditions.

SYSTEM MONITORING

During operation, the WiFi / Ethernet connection or optional touchscreen allows for easy access to all performance data compiled by the HCOM's Delta-T controller. When connected to the internet, facility managers and maintenance crews can remotely monitor and even adjust controls for parameters such as flow, pressure and temperature performance. In the event of any excursion outside of defined limits, email alerts can be sent as notification. With the optional touchscreen, local access to all controls and performance data is possible. A MODBUS protocol tie-in on the controller board supports connection to building automation systems (BAS).



FEATURES	BENEFITS
Delta-T controller with WiFi / Ethernet connectivity	Allows for remote monitoring of flow, pressure and temperature, and for remote access to all controls.
5.6" color LCD touchscreen control (optional)	Local at-a-glance monitoring of system performance and access to all system controls.
Pressure Stagnation Protection (PSP)	Assures glycol will not break down due to fluid stagnation during high temperature conditions.
Variable speed pumps	Improves system optimization and efficiency. Also provides system longevity.
Factory assembled plug & play configuration	Reduces system design and installation times, and assures quality connections.
Building automation system (BAS) tie-in	MODBUS protocol tie-in on Delta-T controller board allows for all data to be recorded and archived when connected to a BAS.
Compact assembly	Small footprint, less floor space required.

TECHNICAL SPECIFICATIONS

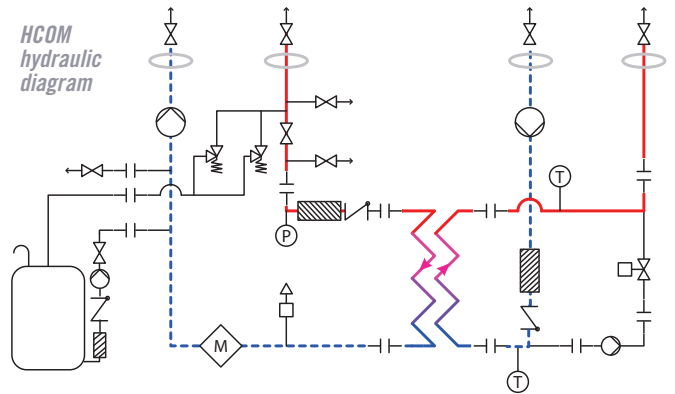
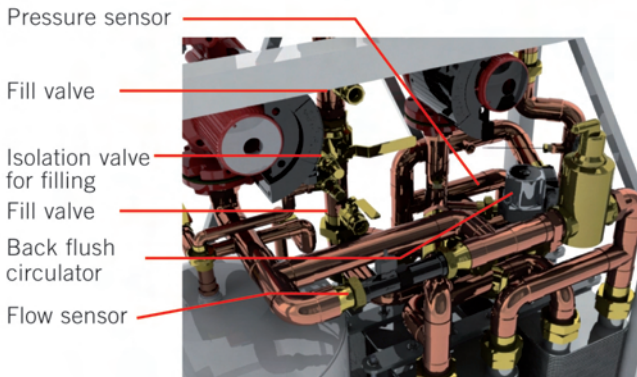
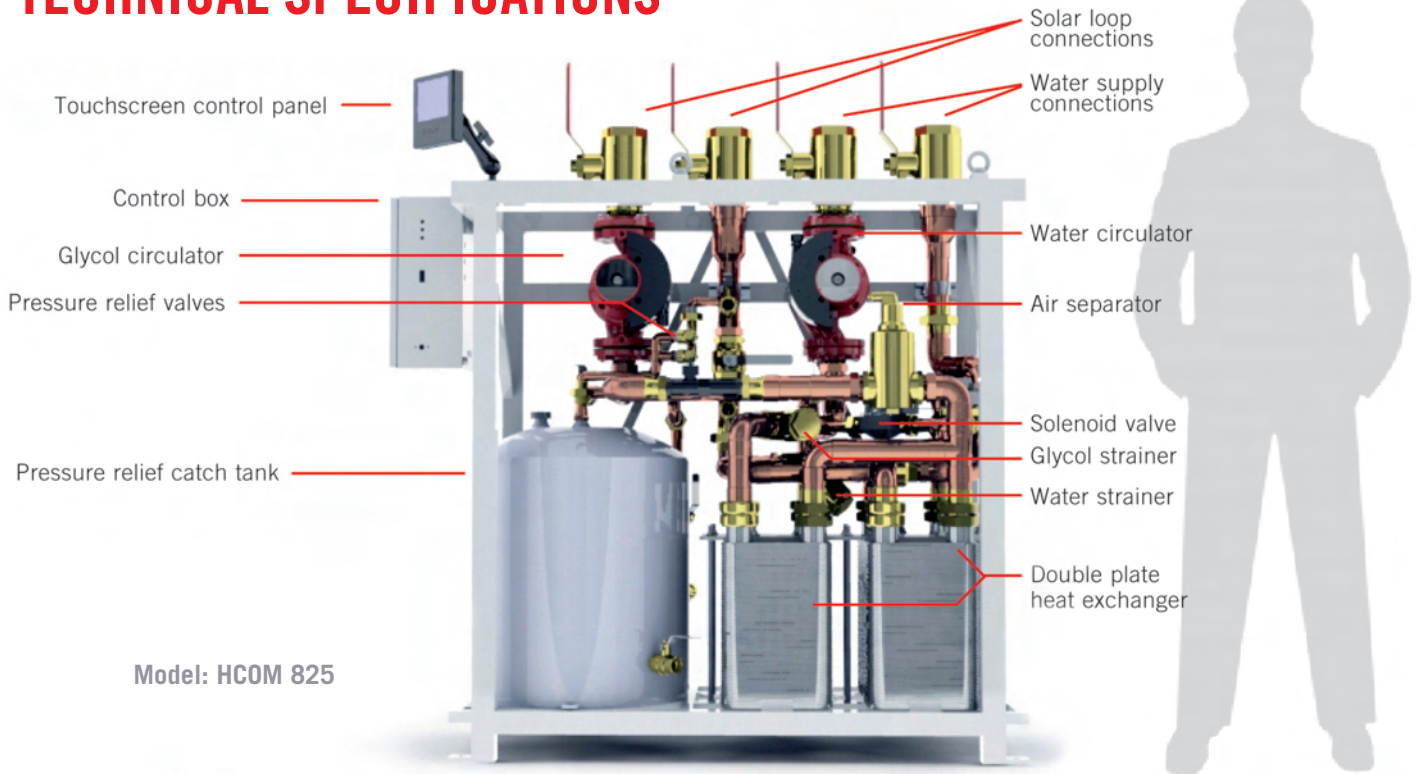

MODEL		HCOM 180*		HCOM 275		HCOM 550		HCOM 825	
Configuration	Heat Exchange	Single Wall	Double Wall	Single Wall	Double Wall	Single Wall	Double Wall	Single Wall	Double Wall
	Touchscreen	000	001	000	001	000	001	000	001
	No Touchscreen	100	101	100	101	100	101	100	101
GOBI 410 Collector Maximum Array		Up to 24		Up to 32		Up to 64		Up to 96	
Frame Dimensions (inches)		(h)50 x (w)22.5 x (d)25		(h)59 x (w)42.5 x (d)25.5		(h)59 x (w)42.5 x (d)25.5		(h)50.5 x (w)50.5 x (d)24.5	
Supply and Return Connections		1.5" NPT		1.5" NPT		2.0" NPT		3.0" NPT	
Supply Voltage		Single phase 230 VAC +/- 2%, 50/60 Hz, 10 amp							
Pressure Rating		150 psig (10 bar)							
Temperature Rating		40 °F (5 °C) to 275 °F (135 °C)							
Included Sensors		5 - 10k ohm sensors, 1 - vortex flow sensor, 1 - pressure sensor							
Warranty		5 year limited (1 year with non-Heliodyne collectors)							

1011_0312_US © 2012 Heliodyne, Inc. • Heliodyne® and Excellence by Design® are registered trademarks of Heliodyne, Inc.

* HCOM 180 configurations do not include domestic hot water back-flush and solar loop catch tank

Heliodyne, Inc. • 4910 Seaport Avenue • Richmond, CA 94804
 T: 510.237.9614 • F: 510.237.7018 • www.heliodyne.com
 Information & Support: info@heliodyne.com

