

INSTALLATION GUIDE

SOLAR HOT WATER MODULE:
SHWM 005 & SHWM 009

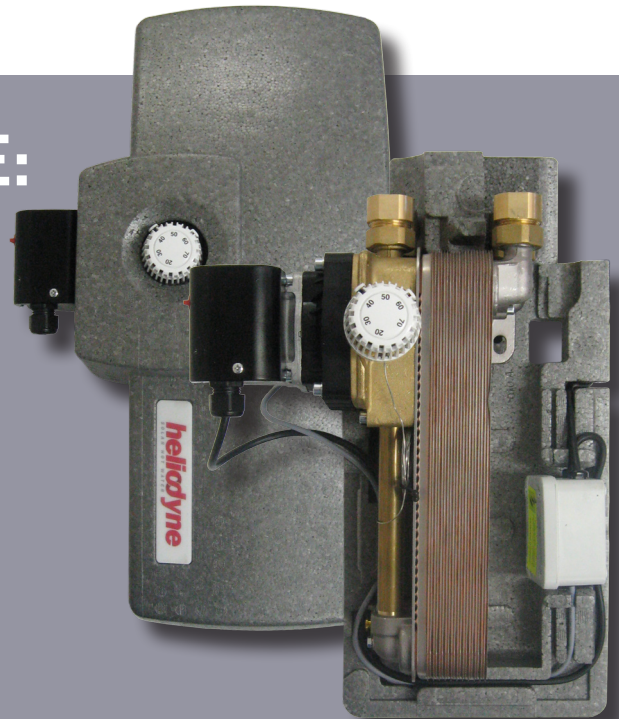

EXCELLENCE
BY DESIGN

SHWM

Safety Precautions

Prior to operation, please read and follow local plumbing guidelines and regulations with regards to but not exclusively to installation of drinking water, heating, solar hot water etc.

The inappropriate use or incorrect changes during the installation and the assembly leads to an exclusion of all liabilities.

The regulations of technology must be respected, as well as the directives of US Federal, State and Municipal authorities.

Table of Contents

Page

Safety Precautions	2
Installation of the module	2
Hydraulic connection	3
Electrical connection	3
Initiation	4
Hot water temperature	4
Circulation	4-5
Technical data	6
Spare parts drawings	7-8
Spare parts list	9
Terms of guarantee	9

Installation

The placement and the installation must be done by an authorized company. For the emplacement location, a frost-proof room is required.

The **wall mounting** is done with the packed mounting material (2x blind screw SSM10x120 VZ; 2x nut M10 DIN934 VZ; 2x flat washer A10,5 DIN125 VZ; screw anchor S12x60). Drill according to the packed drilling-plan on the signed positions with \varnothing 12 mm – approx. 7 cm depth. Put screw anchor in and screw the blind screws into the wall. Now put SHWM on the blind-screws and fix it with flat washers and nuts.

The **tank-mounting** is done with the packed mounting material (2x stud-bolt M10x100 DIN976 4,6 VZ; 2x nuts M10 DIN934 VZ; 2x washer A10,5 DIN 125 VZ). After isolating the tank screw the stud bolts approx. .19 inches into the tank-nuts. For that it is needed to cut carefully the tank-isolation at the perforated area. Now put SHWM on the stud-bolts and fix it with washers and nuts.

Attention: Too strong pulling of screws cause damages on the isolations!

SHWM

Hydraulic Connection

The connection of the pipes takes place according to the clearly visible Index, which is displayed on the module. Please stick to the installation order of galvanized pipes and fittings to avoid electronic corrosion.

We recommend using rinse connections with the cold and warm water connections.

For tank-mounting use the flexible tank-connection-set which is secure and fast.

All flat-gasket connection parts are to be pulled after the pipe work is finished. In wall mounting case the pipings to and from the tank must be min. copper 1.1" (28 mm) to guarantee the max. flow of 740 gal/ min.

The piping should be as short as possible! The use in thermosyphon-systems is not allowed!

CAUTION! Tightening torques or impacts on the pre-assembled components and joints of the module should be avoided!

Electrical Connection

The internal wiring of the electrical installation parts has been performed by the factory. The connection to the power supply network (120 V/AC, 50-60 Hz) occurs through the already wedged network connection.

Work on the live parts of the module should only take place in compliance with the respective instructions of the energy supply company and the legal and relevant regulations.

SHWM

Tip:

Like in all tap water circulation systems a correct overpressure or expansion safety system must be installed.

Initiation

Filling and initiation should be done by an authorized company.

At this time, the functions and the sealing of the entire system, including the parts which were installed by the manufacturer, must be checked.

The delayed opening of the ball valve on the entrances and exits of the module avoids pressure blows during the rinse process. The filling and rinsing has to be performed until the system is completely de-aerated! Audible flow noises during the operation of the trickle charge pump indicate that there is still air in the system, which then has to be drawn off by the pump.

Hot Water Temperature

The regulation of the temperature of the hot water is performed by the thermal default control. This control has been pre-adjusted to a temperature of 131 ° F.

You can limit or fix this setting range by means of the “Memory-Clips” and the limitation pin. Turning clockwise lowers the warm-water temperature. An increase is not advisable because possible calcification could reduce solar energy output. Recommendation for the buffer temperature: This should be approximately 10 K above the desired temperature of the industrial water.

Annual maintenance of the system by an authorized company is recommended.

For more information about installation and initiation, please see our general manual.

Circulation

The SHWM is prepared for optional use with a circulation pump. The circulation pump FWMZP (Art. 130 011) consists a module connection part (Push-In-version), a ball valve and an isolation.

SHWM

For mounting cut the isolation of SHWM in the connection area.

Mounting of isolations.

The following operation modes are selectable by several electric pump in the grey cable box connections:

Time-independent circulation – Circuit I

The circulation pump is enabled by a short actuation of a warm water point of usage and deactivated when the preset circulation runback temperature of the integrated lime protection thermostat is reached. During this operation mode, the clock timer has no relevant function. The clock timer must be set to the “continuous mode”.

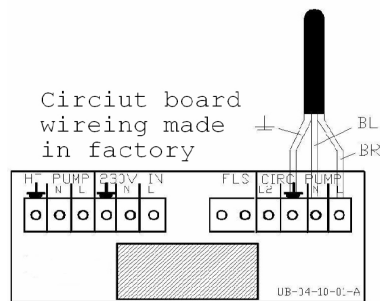

Time-dependent circulation – Circuit



The circulation pump is activated by the individually adjustable clock timer and deactivated when the preset circulation runback temperature is reached. A thermostat provides the synchronized operation of the pump. There is no circulation beyond the preset time zones. The clock timer must be set to the “timer mode”.

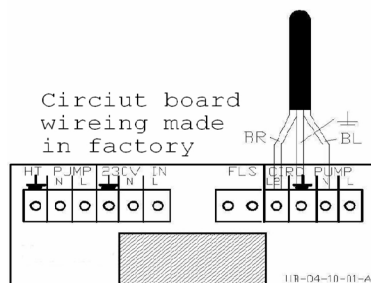

Caution:

During installation of the circulation pump unit, tightening torques and impacts on the already pre-assembled components and joints of the module should be avoided!

Setting of the regulation thermostat

By using a small screwdriver, the arrow should be set to the desired temperature for deactivation. The starting temperature is 5 K below the preset value.

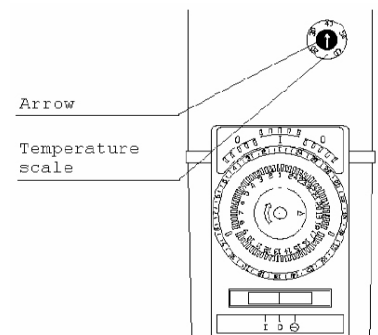

Technical Data

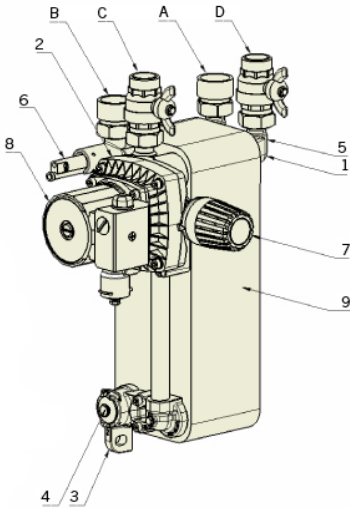

Measurements	Width: 13.26 inches Height: 22.51 inches Depth: 10.86 inches
Cover	EPP, grey
Weight	SHWM 005 - 35 lbs, SHWM 009 - 42 lbs
Connections	A = cold water IN, R 1" B = warm water OUT, R 1" C = From the buffer, Rp 1" D = To the buffer, Rp 1"
Main components	1 = Uni-Block (cold) 2 = Uni-Block (warm) incl. pump 3 = Uni-Block (circulation inlet) incl. Drain 4 = Blind-cap connection (Push-In) 5 = Return valve (built in 1) 6 = Flow switch (built into 2) 7 = Control thermostat head (built into 2) 8 = Loading pump (built into 2) 9 = Plate heat exchanger
Performance	SHWM 005 - 1,5 - 5 gal/min warm water SHWM 009 - 1,5 - 9 gal/min warm water
Min. allowable operating temperature	35 ° F
Max. allowable operating temperature	203 ° F
Max. allowable operating pressure	Tap water 145 PSI Heating 43 PSI
Pump data	Loading pump: 230 V / 50 Rotational frequency = 2200 U/m Power input: SHWM 005 - 25 W, SHWM 009 - 93 W Power = SHWM 005 - 0,1 A, SHWM 009 - 0,4 A

SHWM

Spare Parts - Arrangement Drawings

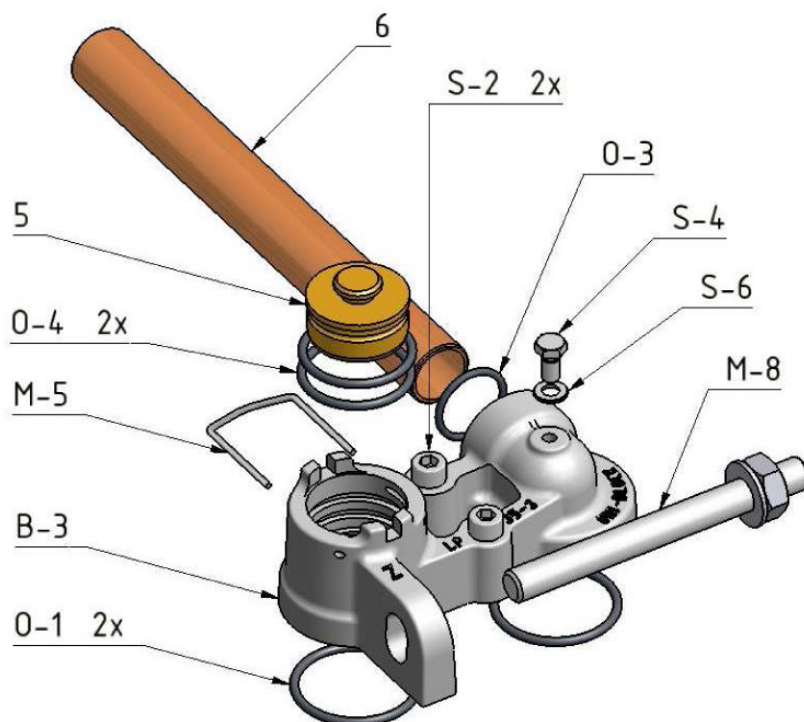
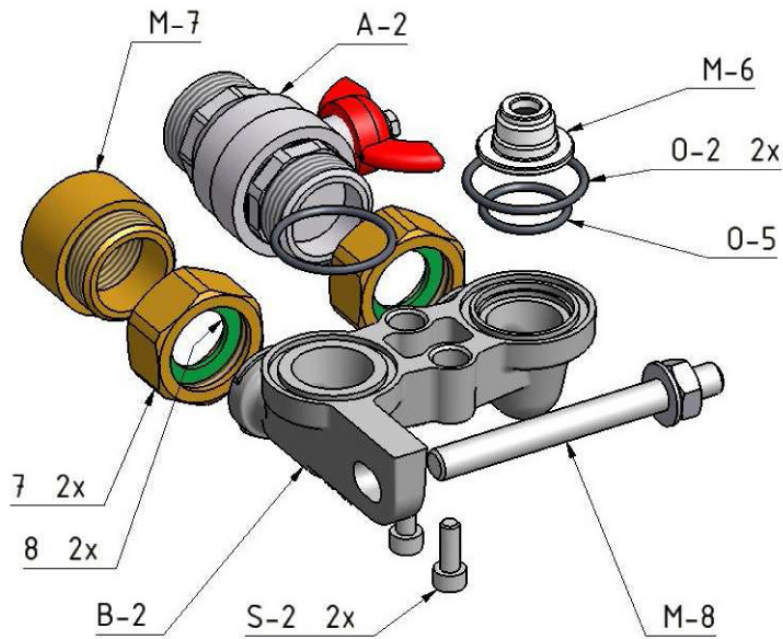

Spare Parts - Arrangement Drawings

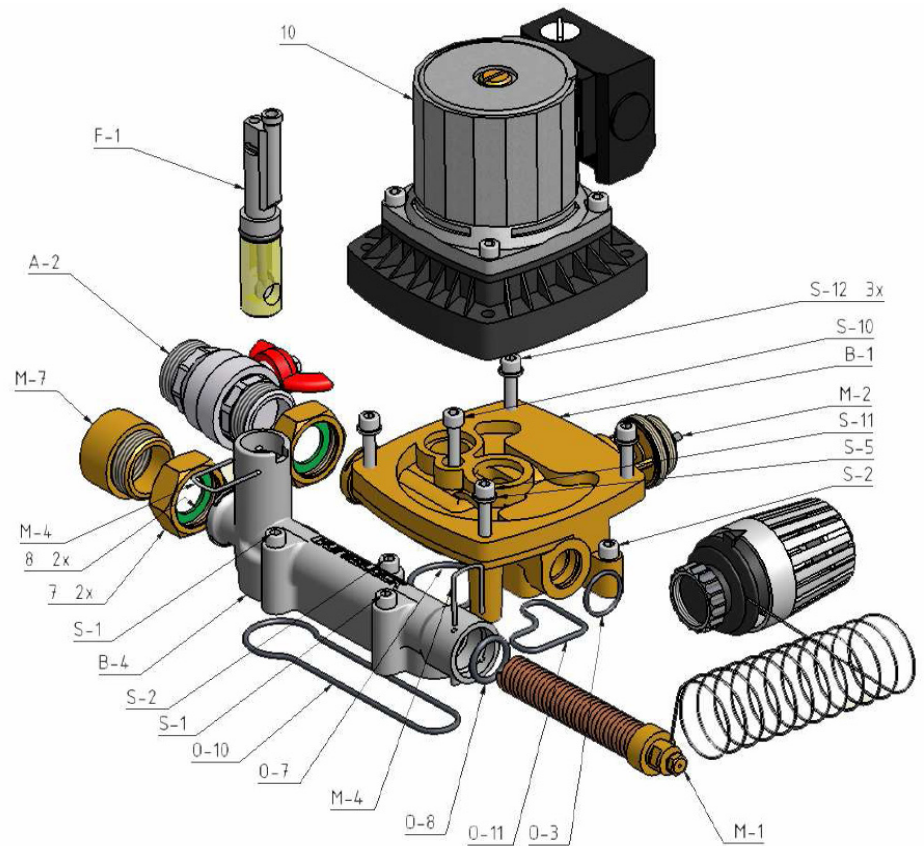

SHWM

Spare Parts

Pos.-No.	Article specification	Article designation	Art. No.
A-1	Isolation SHWM	SHWMIHS	130 097
A-2	Heat ball valve SHWM, Rp 1"-Rp 1", flat sealed	SHWMKH	130 098
E-1	Cablebox SHWM with circuit board	SHWMSB	130 099
F-1	Flowswitch NEW DFS2-Push-IN	SHWMSKS2	130 248
M-1	Control thermostat head SHWM, 20-70 ° C, with integrated coil sensor	SHWMTK	130 100
M-2	Valve barrel SHWM, 1"	SHWMVES	130 101
M-4	Splint A SHWM	SHWMSPLINTA	130 103
M-5	Splint B SHWM	SHWMSPLINTB	130 104
M-6	Plug in check valve SHWM	SHWMRFV	130 105
M-8	Assembly kit (attachment) SHWM	SHWMMS	130 106
O-1 / O-2	O-ring SHWM, 33x2,5	SHWMOR33X25	130 107
O-3	O-ring SHWM, 20x2	SHWMOR20X2	130 108
O-4	O-ring SHWM, 29x2,5	SHWMOR29X25	130 109
O-5	O-ring SHWM, 23x2,5	SHWMOR23X25	130 110
O-7	O-ring SHWM, 36x2,5	SHWMOR36X25	130 112
O-8	O-ring SHWM, 19x3	SHWMOR19X3	130 113
O-10	O-ring SHWM, 19x3	SHWMOR98X25	130 249
O-11	O-ring SHWM, 19x3	SHWMOR40X25	130 250
P-1	Plate heat exchanger SHWM	SHWMPWT2	130 251
B-1	Pressed Brass Block-1 SHWM	SHWMPMB1	130 252
B-2	Pressed Brass Block-2 SHWM	SHWMPMB2	130 253
B-3	Pressed Brass Block-3 SHWM	SHWMPMB3	130 254
B-4	Pressed Brass Block-4 SHWM	SHWMPMB4	130 255
5	End cap circulation port SHWM	SHWMVKZA	130 118
8	Gasket SHWM, 30x20x2	SHWMD30X20X2	130 119
10	Pump SHWM, Typ HU25/6 incl. cable	SHWMUP	130 121
	Screwset Pressed Brass	SHWMPMBSS	130 256

Terms of guarantee

The manufacturer issues a guarantee of 2 years from the invoice date on the module and its constituent parts. A conventional installation and utilization of the module required for a claim under the warranty.

The images shown are symbolic. We ask for forgiveness for possible sentence errors, misprints or ongoing technical variances. Liability can not be assumed because of errors in the contents of this document. The current version of the General Terms of Business are valid.

Heliodyne, Inc. • 4910 Seaport Avenue • Richmond, CA 94804
T: 510.237.9614 • F: 510.237.7018
www.heliodyne.com
Sales Inquiries: sales@heliodyne.com
Information and Support: info@heliodyne.com